

# SECTION 3

---

## Controlling Hazards

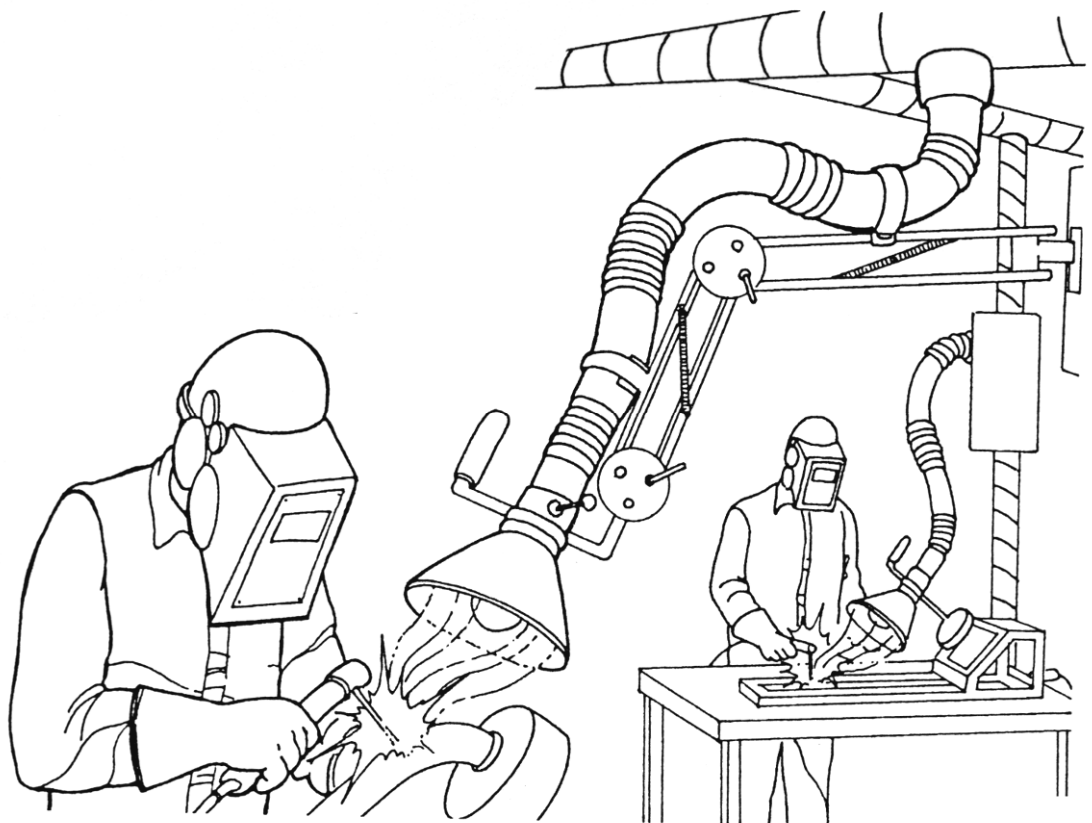



# Section Contents

Controlling Hazards .....	87
Engineering Controls.....	89
Various types of engineering controls methods .....	89
Disadvantages or problems with engineering controls.....	90
Examples of Enclosed Processes .....	91
Examples of Barriers.....	92
Example of Noise Engineering Control.....	93
Examples of Local Exhaust Ventilation (LEV) .....	94
Examples of Ineffective Ventilation.....	95
Recommended Minimum Air Flow Rates for	
Local Exhaust Ventilation (LEV) Systems.....	96
Administrative Controls .....	97
Personal Protective Equipment (PPE) .....	99
The disadvantages of PPE.....	100
Respirators.....	101
Types of Respirators .....	102
Air Purifying Respirators .....	103
Air-Supplied Respirators.....	104
What Else Do You Need to Know About Respirators?.....	104
Selecting the Right Respirator .....	105
Test the Respirator Fit .....	106
Always Check the Face Seal.....	106
Positive Seal Check.....	107
Negative Seal Check .....	107
Caring For Your Respirator .....	108
Limitations of Respirators.....	109
Respiratory Protection.....	110
Respiratory Protection Checklist .....	111
Chemical Protective Clothing (CPC).....	112
Using the Right Glove .....	113
Glove/Hand Protection.....	117
Glove/Hand Protection Checklist .....	118
Key Points.....	119
Notes .....	120



# Controlling Hazards

---

Workers can't be protected until hazards have been identified and evaluated. Then, various methods of protecting workers — called “controls” — can be put into place. There are three types of controls:



Engineering Controls



Administrative Controls



Personal Protective Equipment

All three types of controls can be used together, but the priority is always to use the engineering controls before all others. Administrative controls and Personal Protective Equipment (PPE) should not be used until engineering controls have been tried, unless engineering controls are not possible.

The most effective approach to worker protection is:

Control the hazard, not the worker.

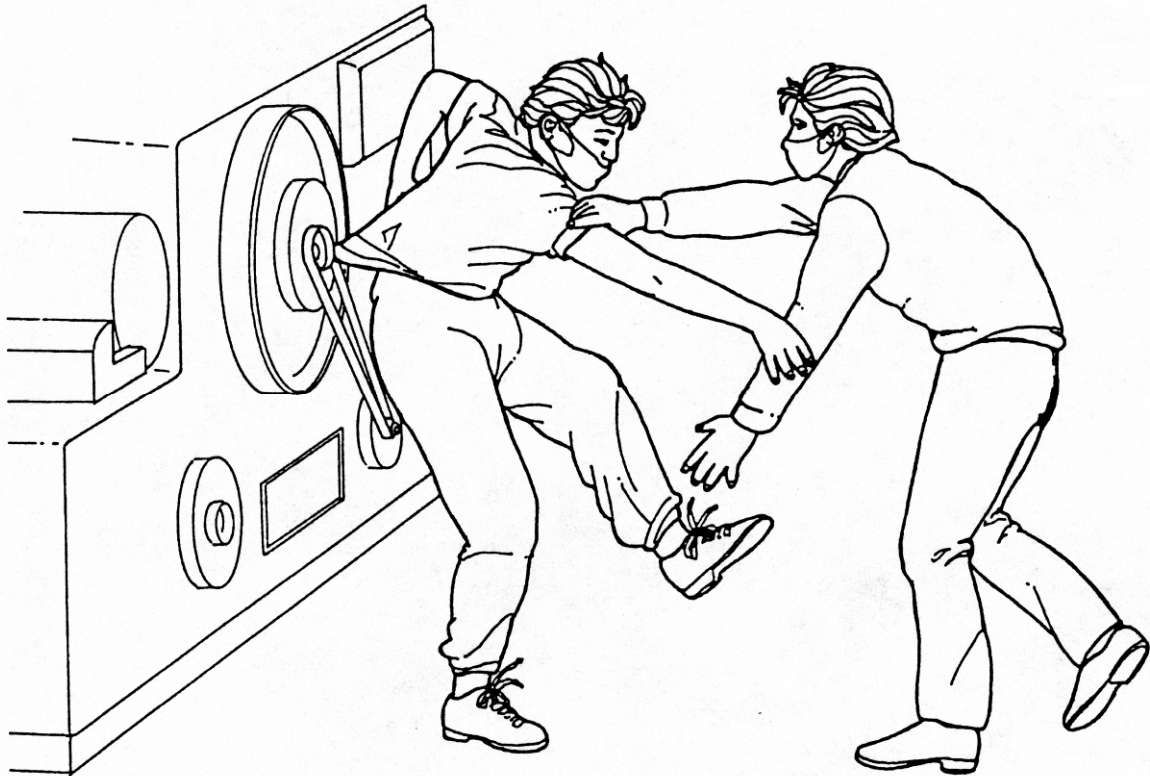

## Engineering Controls

Engineering controls are considered the best form of controls because they eliminate the hazard altogether or eliminate the worker's exposure to the hazard. Engineering controls directly address the hazard and they do not depend on workers' actions to be effective.

The various types of engineering controls include methods to:

- redesign the process, such as:
  - ⇒ replacing gasoline motors with electric motors to eliminate exhaust fumes;
  - ⇒ installing automatic feeding equipment on machines to protect hands;
  - ⇒ using wet methods to reduce dust levels;
- mechanize the process, such as:
  - ⇒ conveyor belts to eliminate dusts caused by shoveling;
- substitute safer products for more hazardous ones, such as:
  - ⇒ using chemicals that are less toxic, less dusty, or less volatile;
  - ⇒ replacing old equipment with newer equipment with built-in guards;
- isolate the process or isolate the worker from the process, such as:
  - ⇒ installing enclosures on noisy equipment;
  - ⇒ constructing a control room where workers are protected against noise, heat, or toxic emissions;

- install “local exhaust ventilation” (LEV), such as:
  - ⇒ ventilation systems installed directly on chemical tanks;
  - ⇒ welding tables and work stations to carry away airborne hazards from right where they are created.

The advantages of engineering controls are that they eliminate the hazard altogether, or eliminate the worker’s exposure to that hazard.

There are disadvantages or problems with engineering controls.

These include:

- engineering controls can be very expensive and may be difficult for small employers to install;
- some hazards do not have technological solutions at this time;
- enclosures or isolation of the hazard do not eliminate the hazard, so that workers can still be exposed in the event of an accident or leak;
- substitution of one chemical or machine for another one may expose workers to different hazards created by the new product or machine;
- ventilation systems must be maintained and tested regularly to remain effective.
- engineering controls like ventilation or mechanization have to be maintained or repaired, which can expose maintenance mechanics to the hazard.

Examples of engineering controls are shown on the next five pages.



## Examples of Enclosed Processes

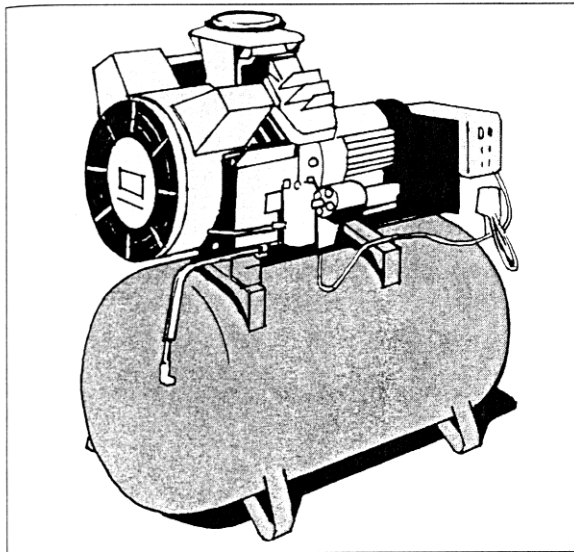
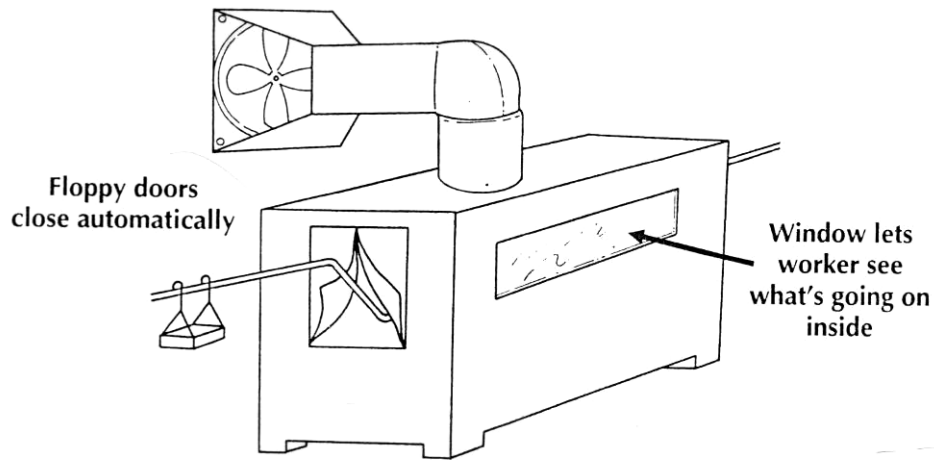

Noise-insulated air compressors. The principle is that the noise should be contained under the hood. The hood is made of hard material with a soft, absorbent lining

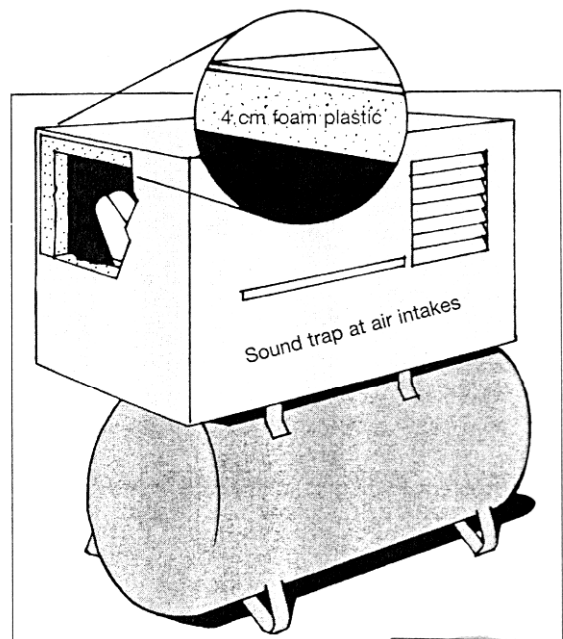

## Examples of Barriers

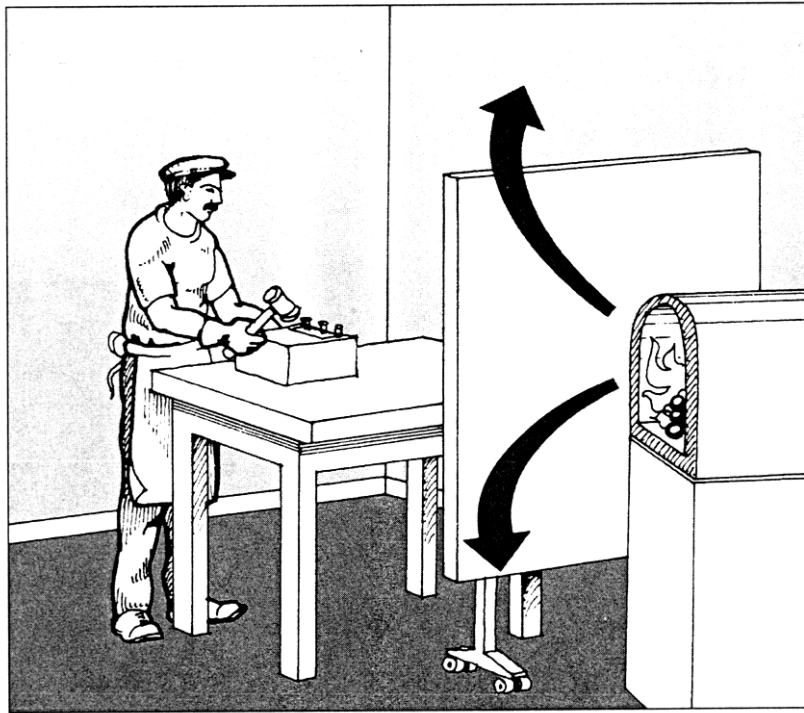

**Heat barriers prevent radiant heat from reaching the worker, which reduces heat stress**

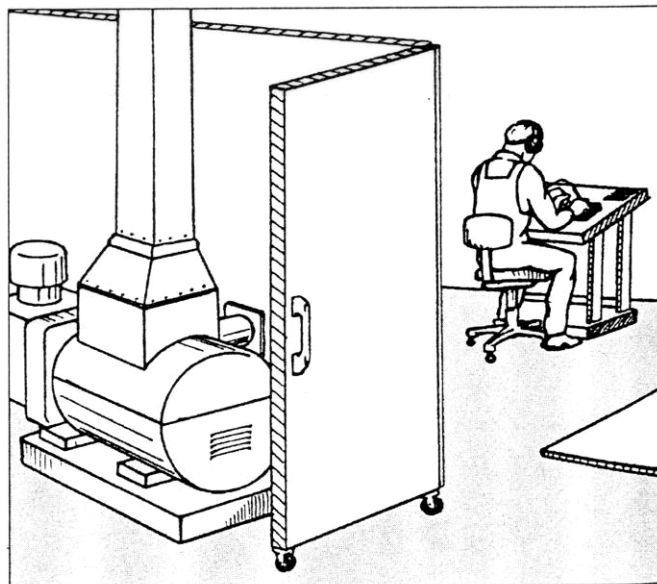

**Hearing protection by isolating noisy machines.**

## Example of Noise Engineering Control

Noise is trapped and absorbed in “baffles” or panels in ceiling

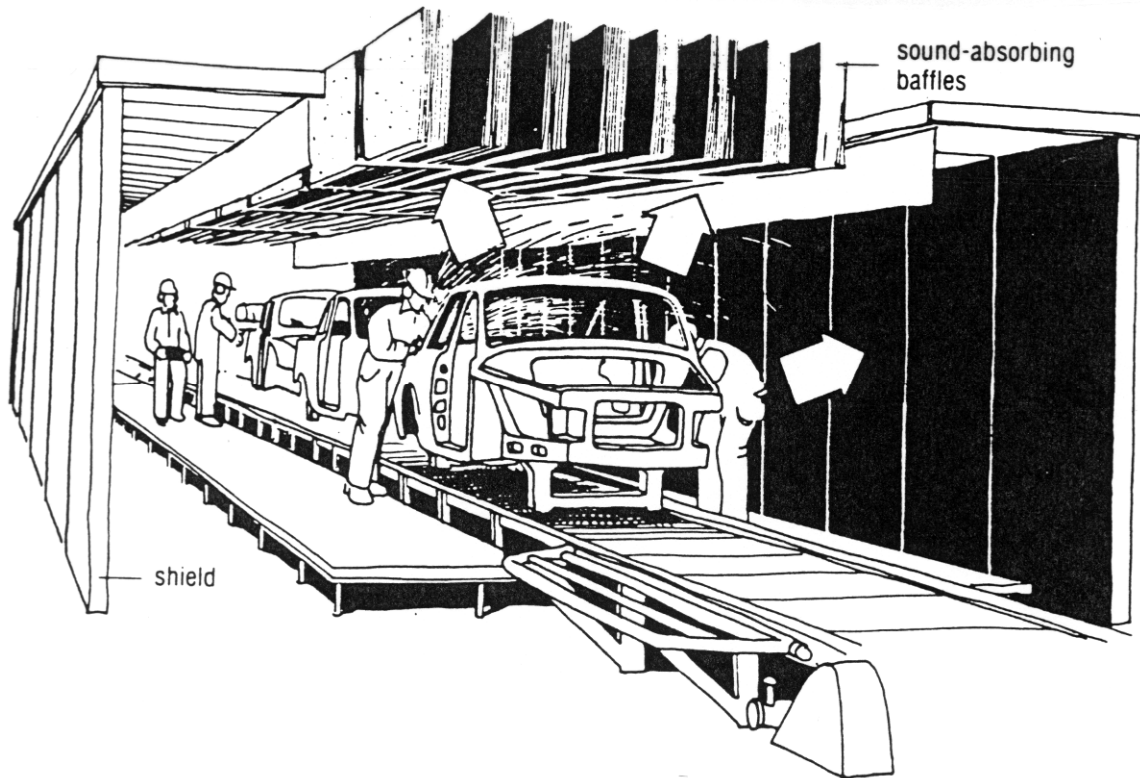

## Examples of Local Exhaust Ventilation (LEV)

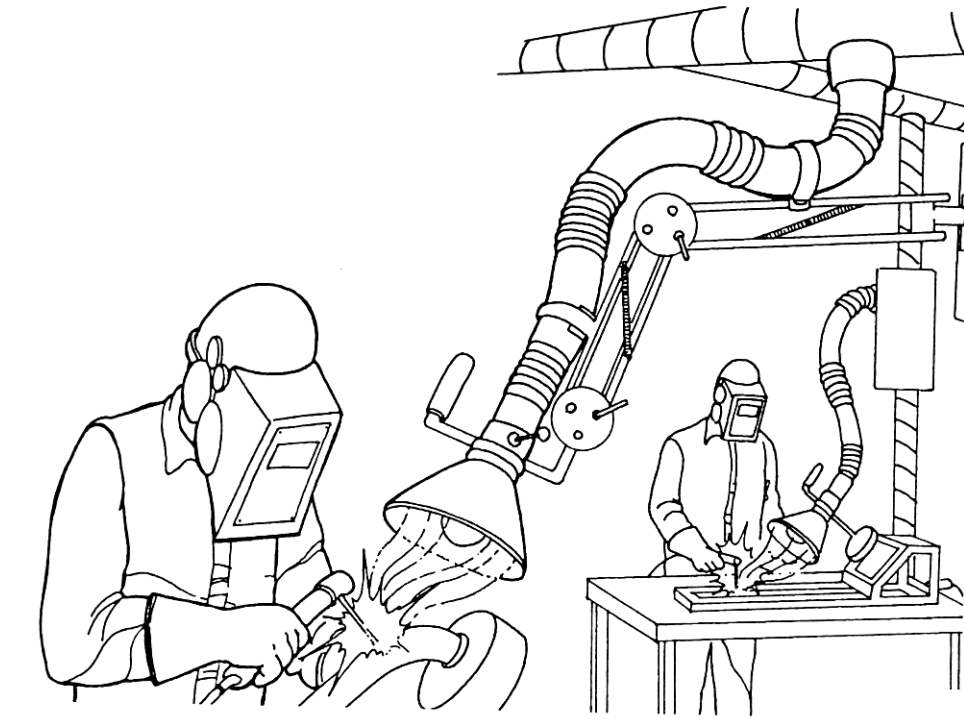
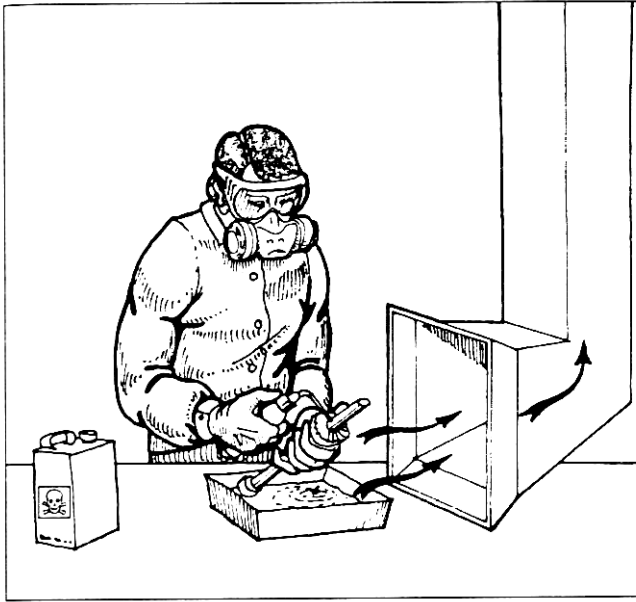

## Examples of Ineffective Ventilation

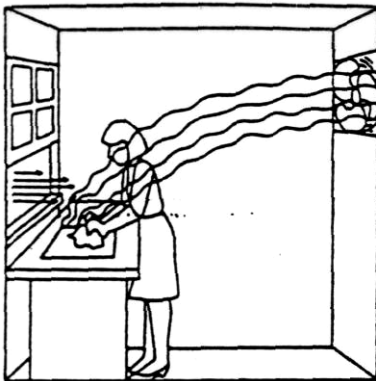

Ineffective

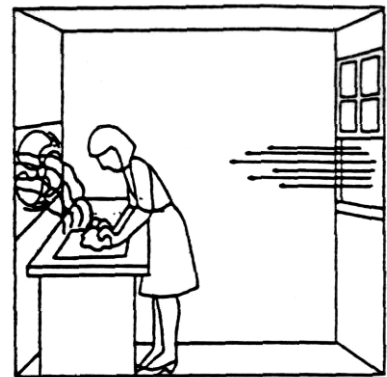

Effective

## Recommended Minimum Air Flow Rates\* for Local Exhaust Ventilation (LEV) Systems

Air flow rates recommended by the American Conference of Governmental Industrial Hygienists (ACGIH)

<b>How contaminant released</b>	<b>Example</b>	<b>Lower End**</b>	<b>Higher End***</b>
Released with practically no velocity into quiet air	Evaporation from tanks; degreasing, etc	50 fpm 15.2 mpm	100 fpm 30.5 mpm
Released at low velocity into moderately still air	Spray booths; intermittent container filling; low speed conveyor transfers; welding; plating; pickling	100 fpm 30.5 mpm	200 fpm 61 mpm
Active generation into zone of rapid air motion	Spray painting in shallow booths; barrel filling; conveyor loading; crushers	200 fpm 61 mpm	500 fpm 152.4 mpm
Released at high initial velocity into zone at very rapid air motion	Grinding' abrasive blasting; tumbling	500 fpm 152.4 mpm	2000 fpm 610 mpm

\* Air flow rates measured in feet per minute (fpm) or meters per minute (mpm)

\*\* Lower air flow rates acceptable only if:

- Room air currents minimal or favorable to capture contaminant
- Contaminants of low toxicity or of nuisance value only
- Intermittent, low production

\*\*\* Higher air flow rates required if:

- Disturbing room air currents
- Contaminants of high toxicity
- High production, heavy use
- Small hood-local control only

Article 24 of China's 1994 Labor Law (effective January 1, 1995) requires that ventilation systems be inspected, repaired and cleaned on a regular basis.

## Administrative Controls

Administrative controls do not eliminate the hazard but are used to limit the time of exposure that each worker is exposed to the hazard. Administrative controls depend on human action to be effective.

The various types of administrative controls include methods to:

- rotate workers between a hazardous task and a non-hazardous task so that the time of exposure to the hazard is reduced;
- increase the number of breaks to reduce the time of exposure;
- change the schedule of work, if possible: such as scheduling tasks with heat stress hazards to occur at night when the ambient temperatures are cooler;
- keep areas free of clutter and debris (good housekeeping) to reduce the possibility of accidents and fires, to protect tools and equipment, and to prevent accumulation of toxic materials;

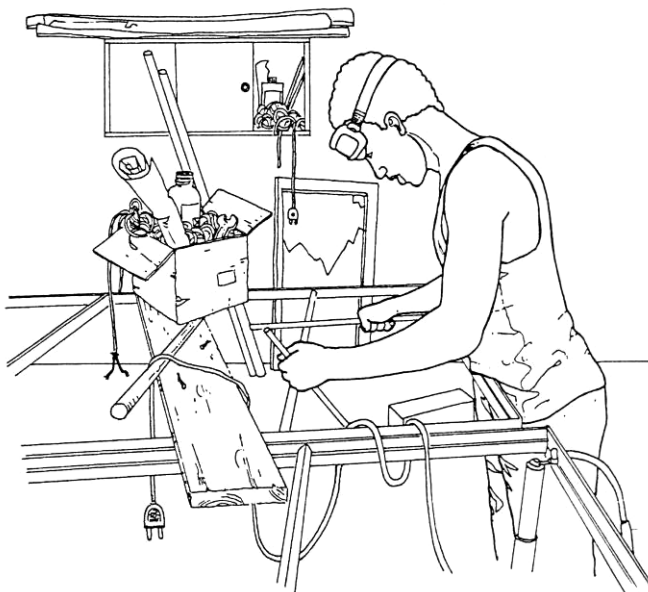

---

**Poor housekeeping.**

Good housekeeping and storage tubs would help protect this worker.

---

- improve personal hygiene facilities and practices to allow workers to wash hands and faces before eating and drinking, prohibit food consumption in work areas, and to allow workers to shower after the shift and leave contaminated clothes at the workplace;
- improve worker training and work practices to increase workers' ability to recognize and evaluate hazards, and to take action to protect themselves.
- provide frequent rest periods.

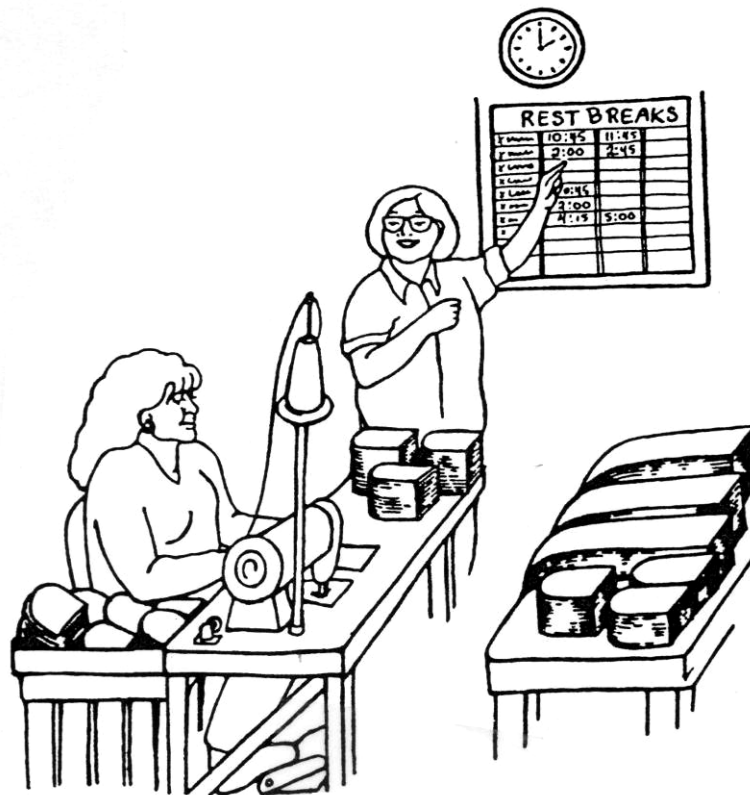

There are disadvantages or problems with administrative

controls. Hazardous exposures continue to occur, but workers' exposure time is reduced. Job rotation reduces the time of exposure for one worker but it also increases the total number of workers who are exposed. Like any process which involves human beings, human error can occur and result in hazardous exposures.



## Personal Protective Equipment (PPE)

Use of personal protective equipment (PPE) is considered the weakest form of control. PPE should be used as the principal means of control only as a last resort when neither engineering nor administrative controls are possible, or in the event of emergencies.

PPE does not eliminate the hazard or reduce the time of exposure. PPE simply reduces the amount of hazardous exposure by placing a barrier between the hazard and the worker. There are many factors that can reduce the effectiveness of the barrier. PPE depends entirely on human action to be effective.

The various types of PPE include equipment to protect the head, ears, eyes, respiratory system (through the nose and mouth), hands, body and feet.

Examples of PPE include:

▶ protective suits



▶ ear protectors

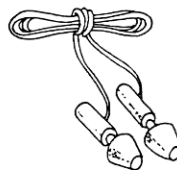

▶ safety glasses



▶ dust masks



▶ respirators with filters



▶ safety shoes

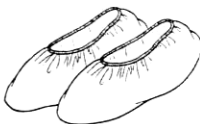

▶ gloves



The disadvantages of PPE as a hazard control include:

- most PPE available has been designed for the dimensions of workers in Canada, Europe and the United States, and may not fit workers in other parts of the world;
- PPE must be the specific type needed for the particular hazard;
- PPE must be used correctly, inspected often, and maintained in good order;
- some PPE, such as respirator filters and gloves, must be replaced frequently to maintain an effective barrier against the hazard;
- some PPE creates its own health and accident hazards, such as increased heat stress, reduced visibility and hearing capacity, reduced grip capacity for hands, potential for ear infections, and increased discomfort from use of cumbersome equipment.

The use of PPE is not an effective control of workplace hazards without the correct equipment and worker training in its use, care and storage.

# Respirators

What is a respirator?

A respirator is an enclosure that covers the nose and mouth, or the entire face or head and forms an air-tight seal around the nose and mouth.

When should you use a respirator?

Respirators can be hot and uncomfortable. You don't want to wear one if you don't have to. They also aren't as effective as some other kinds of protection. But if there is no way to remove a harmful material from the air you are breathing (by using a safer chemical, better ventilation or other controls), you will need to use a respirator to protect yourself.

Which kind of respirator should you use?

The type of respirator you need depends on:

- what hazard you are exposed to, and
- how much of it you are exposed to

No one respirator is right for all kinds of hazards.



## Types of Respirators

### Dust mask

- Dust masks protect against wood dusts and other dusts that are not very toxic.
- Dust masks will not protect you against spray mists or toxic dusts like asbestos, silica or lead.
- They will not protect you against chemical vapors or second-hand smoke.

### High Efficiency Particulate Filters

- High Efficiency Particulate filters can remove 99.9% of particles you breathe.
- They are actual cartridges that fit on an air purifying respirator (see next page).

### If you use a dust mask

- make sure it has a double strap
- a good nose grip, and
- is approved by “NIOSH” for “dusts, fumes, and mists”.

Never rely on single strap dust masks.



Dust Mask

## Air Purifying Respirators

Air Purifying Respirators (called APRs) use cartridges to filter the air before you breathe it.

There are three different kinds of filters or cartridges:

1. Particulate cartridges protect against dusts, metal fumes and mists. They will not protect you against vapors or gases.
2. Chemical cartridges protect against toxic gases and vapors from solvents or paints. They will not protect you against dusts or fumes.
3. Combination cartridges protect against dusts, vapors, fumes and mists. Combination cartridges are available for any set of inhalation hazards.



**APRs will not protect you if there is not enough oxygen.**

## Air-Supplied Respirators

Air-supplied respirators give you fresh air from a tank or through an airline. Use them when you work in a confined space where there is not enough oxygen to breathe or where there are high levels of toxic gases.

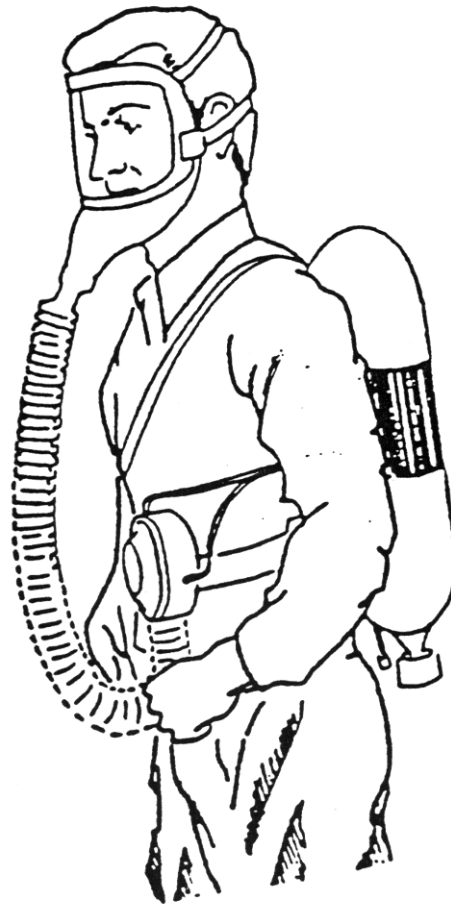

## What Else Do You Need to Know About Respirators?

Once you know what kind of respirator you need for the particular job you're doing, you still need to:

- **Make sure your respirator fits properly.**  
No one respirator will fit everyone. If your respirator does not fit properly on your face, it will leak. You cannot tell if it fits by how it feels. The law in the United States requires your employer to test the fit to make sure no vapors or dusts can leak in around the edges.
- **Make sure your respirator is maintained properly.**  
Your respirator must be kept clean, and the cartridges or filters should be changed regularly. A respirator with a worn-out cartridge is worse than no respirator at all. (It's not protecting you, but it's making it harder to breathe.)

## Selecting the Right Respirator

Like shoes, respirators come in different shapes and sizes. A respirator has to fit well to provide good protection.

- Your employer must check the fit of your respirator before you wear it.
- The fit of each respirator should be tested every six months.
- Wearers should check the respirator face seal every time they put it on.

### 1. Select Size and Shape

Respirator size and shape should be selected to fit snugly but comfortably. Shake your head. Respirator should stay in place.

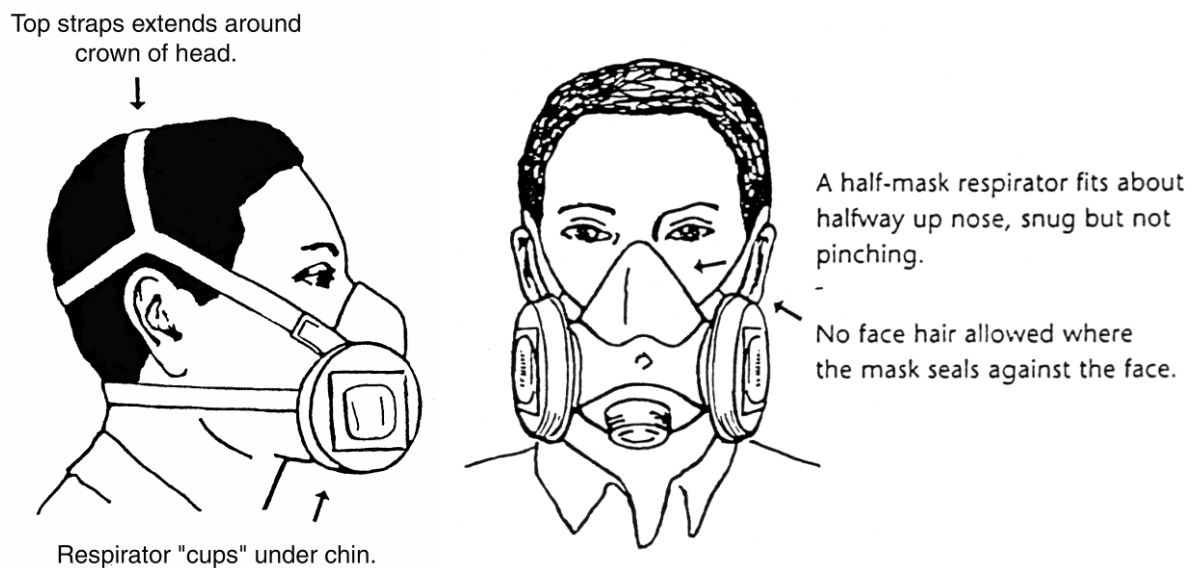

## 2. Test the Respirator Fit

A respirator program requires that the employer test and fit the respirator. There are two kinds of fit tests. Both test how much the respirator leaks around the face seal.

- The “qualitative” fit test is simple and inexpensive to do. A testing chemical with a strong smell or taste is released around the respirator face seal. If the wearer can smell or taste the chemical, the respirator has failed the fit test.
- The “quantitative” fit test uses electronic equipment to measure how much the respirator leaks. The advantage of this test is that it tells you how well the respirator fits. This allows you to compare different respirators and select the one that fits best.



---

TEST THE RESPIRATOR FIT.

---

## 3. Always Check the Face Seal

It is important to do a “user seal check” every time you put on a respirator. Getting into the habit is the best thing a wearer can do to ensure good protection.



## Positive Seal Check

- Cover the exhalation valve with the palm of your hand.
- Inflate the mask slightly by exhaling gently. Hold your breath.
- If air leaks out and the mask deflates, adjust the straps and try again.
- If the face seal holds the air and the mask stays inflated, it has passed the positive face seal check.



Positive Seal Check

## Negative Seal Check

- Cover the filters so that air cannot be drawn through them.
- Collapse the mask against your face by inhaling gently. Hold your breath for 10 seconds.
- If air leaks in and the mask re-inflates, adjust the straps and try again.
- If air does not leak in and the mask stays collapsed against your face, it has passed the negative face seal check.



Negative Seal Check

## Caring For Your Respirator

In order to protect you, your respirator needs to be cared for properly. This includes

- Regular inspection;
- Replacement of parts such as valves, filters, etc.;
- Cleaning and sanitizing; and
- Proper storage.

### Cleaning

The respirator facepiece should be cleaned and disinfected regularly. Each respirator should be cleaned and sanitized before worn by another individual. They should be air dried after washing. Manufacturer guidelines should be followed when cleaning respirators.



Respirators must be cleaned and disinfected.

### Storage

Respirators should be stored in clean environments with the cartridges removed. They should not be exposed to extreme temperatures or moist environments. The rubber should not be distorted when stored.

*\*Source of graphics: North Safety Products*

## Limitations of Respirators

- Respirators do not correct the problem. The chemicals are still in the air and can still be dangerous.
- Respirators do not protect you from chemicals that damage your skin, or that go through your skin.
- You can not get an air tight seal if you have a beard or sideburns.
- Respirators are uncomfortable, hot and stressful.
- Wearing a respirator can increase the risk of accidents. When you wear a respirator it is harder to see, hear, talk, and move.
- Workers who use respirators must be “medically fit.”
- Respirators can give you a false sense of security. A respirator that doesn't fit, or is not in good condition, can't protect you. Using a worn-out cartridge, or the wrong cartridge for the chemical, won't protect you either.



## RESPIRATORY PROTECTION



Questions to Ask Before You Wear a Respirator:

1. What's the name of the chemical?

---

---

2. When and how am I exposed to this hazard?

---

---

3. Has my employer done air monitoring?

' YES   ' NO   ' I DON'T KNOW

4. Have I seen the air monitoring results?

' YES   ' NO

5. Has my employer tried control or eliminate this hazard using engineering or administrative controls?

' YES   ' NO   ' I DON'T KNOW

6. Have I seen the Material Safety Data Sheet or a label with information about this chemical?

' YES   ' NO

## RESPIRATORY PROTECTION CHECKLIST

Make sure that you can check off all of these boxes/steps before you put on a respirator. If you have boxes without check marks, see Action Steps section below.

- 1. I've had a medical exam, paid for by my employer, before being fit-tested for a respirator. (Note: A fit-test involves testing the respirator to make sure there are no leaks.)
- 2. I've been fit-tested for a half-mask or full-face respirator.
- 3. My employer has trained me on how to use a respirator correctly, including:
  - How to do a positive/negative pressure test.
  - How to clean and store my respirator.
- 4. I've been trained on how to use respirator cartridges, including:
  - How to make sure the cartridge fits securely in my respirator.
  - How to match a specific cartridge to a specific chemical to prevent exposure.
  - How often I need to change the cartridge.

### Action Steps:

If you were unable to check off any of the above steps, what actions do you need to take before wearing a respirator?

1. \_\_\_\_\_
2. \_\_\_\_\_

## Chemical Protective Clothing (CPC)

1. Personal Protective Equipment (PPE) includes all protective devices that workers use on the job. This includes:
  - respirators
  - safety equipment and
  - chemical protective clothing.
2. Chemical Protective Clothing (CPC) is specifically designed to prevent exposure to hazardous chemicals. CPC may include
  - goggles
  - a face shield
  - an apron
  - gloves
  - boots and a suit

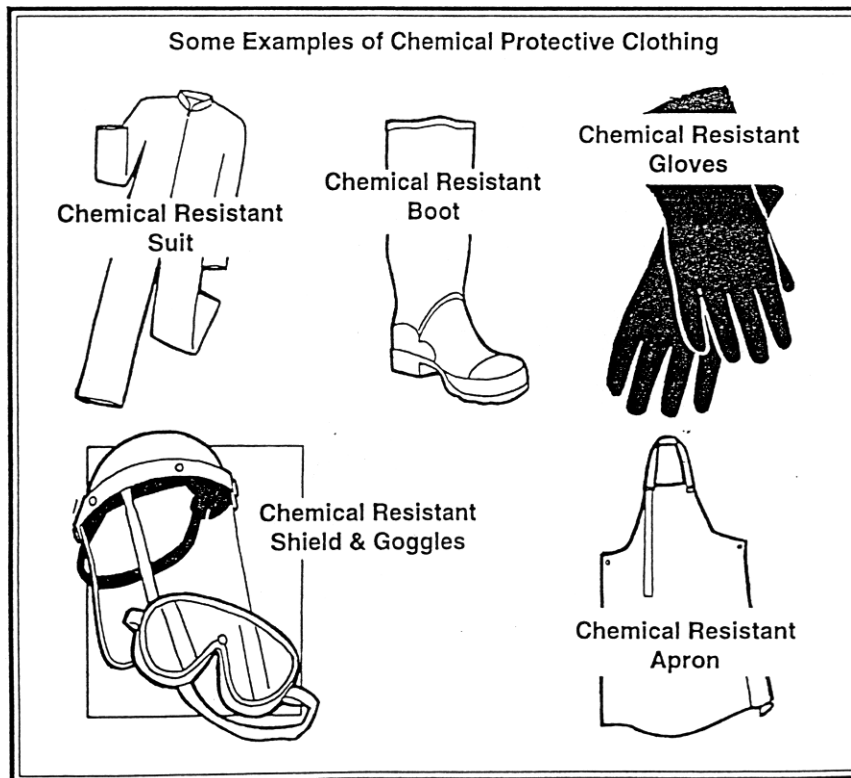

## Using the Right Glove

Chemical gloves are made from various materials. Different materials give better protection against different chemicals.

Chemicals can get through in three ways:

- Permeation is the process by which a chemical passes through protective clothing material at a molecular level.
- Degradation is the loss of, or change in, the fabric's chemical resistance.
- Penetration is the movement of chemicals through zippers, stitched seams, or imperfections in a protective clothing material.



Chemical resistance is the ability of the clothing or material to prevent or reduce exposure to chemicals. All materials are subject to some degree of degradation or permeation and penetration.

The time it takes a chemical to permeate a material is called the breakthrough time. Breakthrough may be immediate or take more than 24 hours. The actual breakthrough time depends on the suit material and the chemicals involved. You want material which has a breakthrough time greater than exposure time. Permeation data should be provided by the manufacturer.

A glove chart can help you pick the proper glove. Glove charts often use a color code. The color tells you whether a glove will protect you.

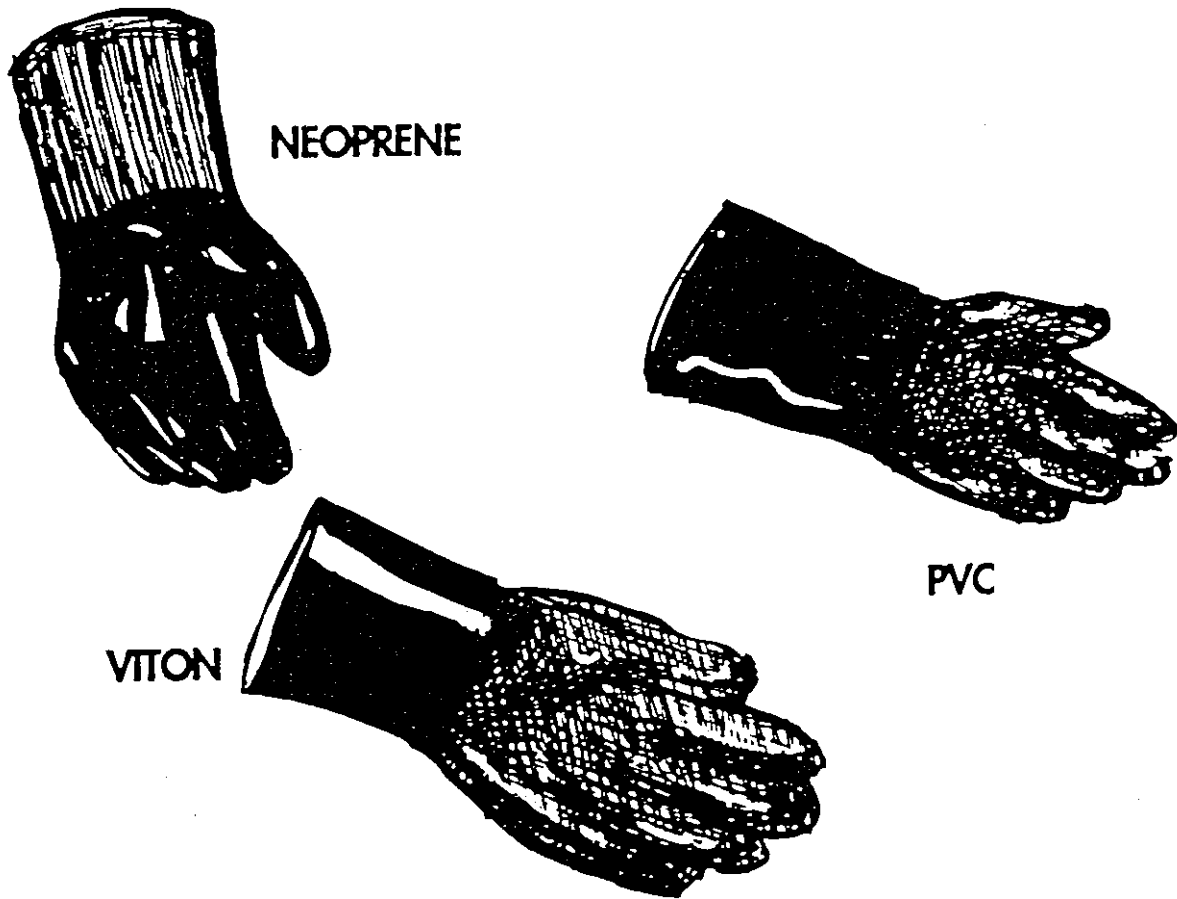



ONE EXAMPLE OF A GLOVE CHART  
(From the North Company)

Glove charts use a color code. The color tells you whether a glove will protect you from hazardous chemicals.

Green - Good - This glove will protect you

Yellow – Warning – OK only for a short time

Red – Don't use this glove

Chemical	Butyl	Silver Shield	Nitrile	Viton
Acetone	Green	Green	Red	Red
Nitric Acid	Yellow	Green	Red	Yellow
Toluene	Red	Green	Red	Green

### Section Three: Controlling Hazards

## GLOVE/HAND PROTECTION



### Questions to Ask Before You Wear Gloves?

1. What's the name of the chemical?

---

---

---

2. When and how am I exposed to this hazard?

---

---

---

3. Have I seen the Material Safety Data Sheet or a label with information about this chemical?

' YES ' NO

4. Has my employer tried to control or eliminate this hazard using engineering or administrative controls?

' YES ' NO

## GLOVE/HAND PROTECTION CHECKLIST

Make sure that you can check off all of these boxes/steps before you wear gloves. If you have boxes without check marks, see Action Steps section below.

- 1. I've been trained on how to understand a glove manufacturer's selection chart, including:
  - How to match the correct glove to a specific chemical exposure.
  - How long a particular glove protects against a specific chemical exposure.
  - When and how to get a new pair of gloves.
  
- 2. My gloves are the right size and length, allowing me to do my work safely and comfortably while I'm wearing them.
  
- 3. I know how to:
  - Inspect gloves for rips, tears and/or holes before I put them on, and again when I take them off.
  - Take off my gloves to avoid exposing myself to chemicals.
  - Clean and store my gloves after I use them.
  
- 4. My work place has a sink where I can wash my hands before I put on my gloves, and again after I take them off.

### Action Steps:

If you were unable to check off any of the above steps, what action do you need to take before wearing gloves?

1. \_\_\_\_\_

2. \_\_\_\_\_



## Key Points

- 1) All workplace hazards can be controlled by one method or a combination of methods.
- 2) The most effective control measure is to control the hazard by engineering controls such as redesign, substitution, enclosure and isolation, and ventilation.
- 3) Use of PPE is the weakest form of control and should be the last choice.

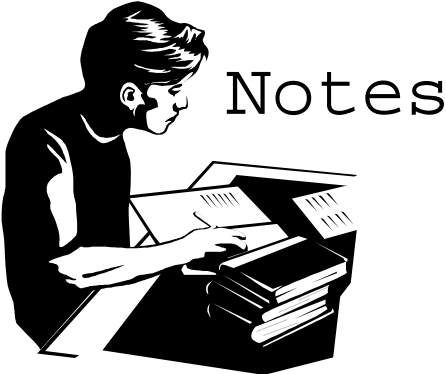

---

---

---

---

---

---

---

---

---

---

---

---

---

---

---

---

---

---

---

---

---

---

---

---

---

---

---

---

---

---